

PRESENTATION FOR 2K TOOLS BUILT BY DEMA

HTA-45 A096 Audi TT Abdeckkappe FS + BFS

1+1 IMPRESSIONS

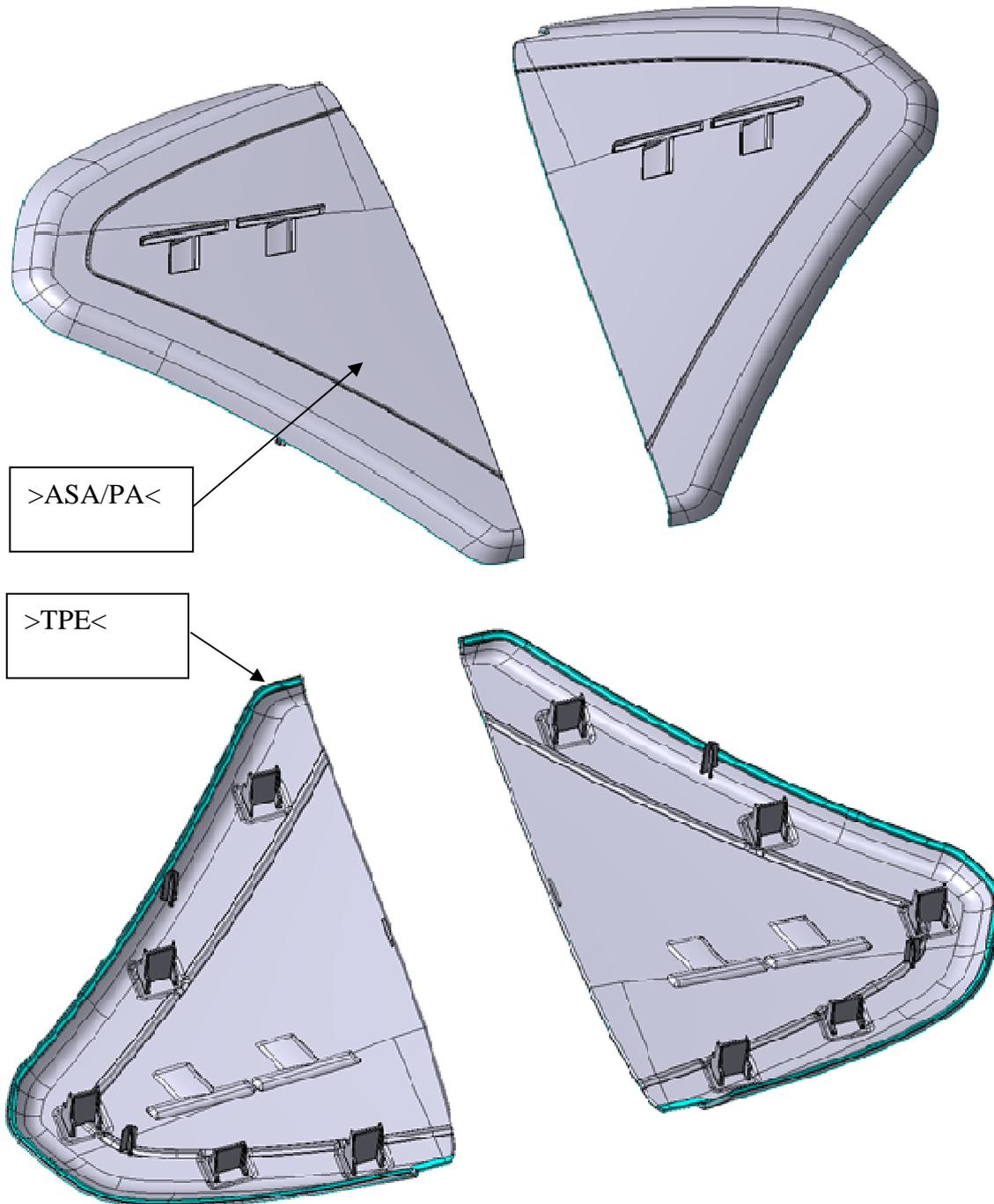

- TOOL WITH BLADES MOVED BY HYDRAULIC CYLINDER
- TOOL SIZE 746X646X780H mm,
- PRESS ENGEL 400t

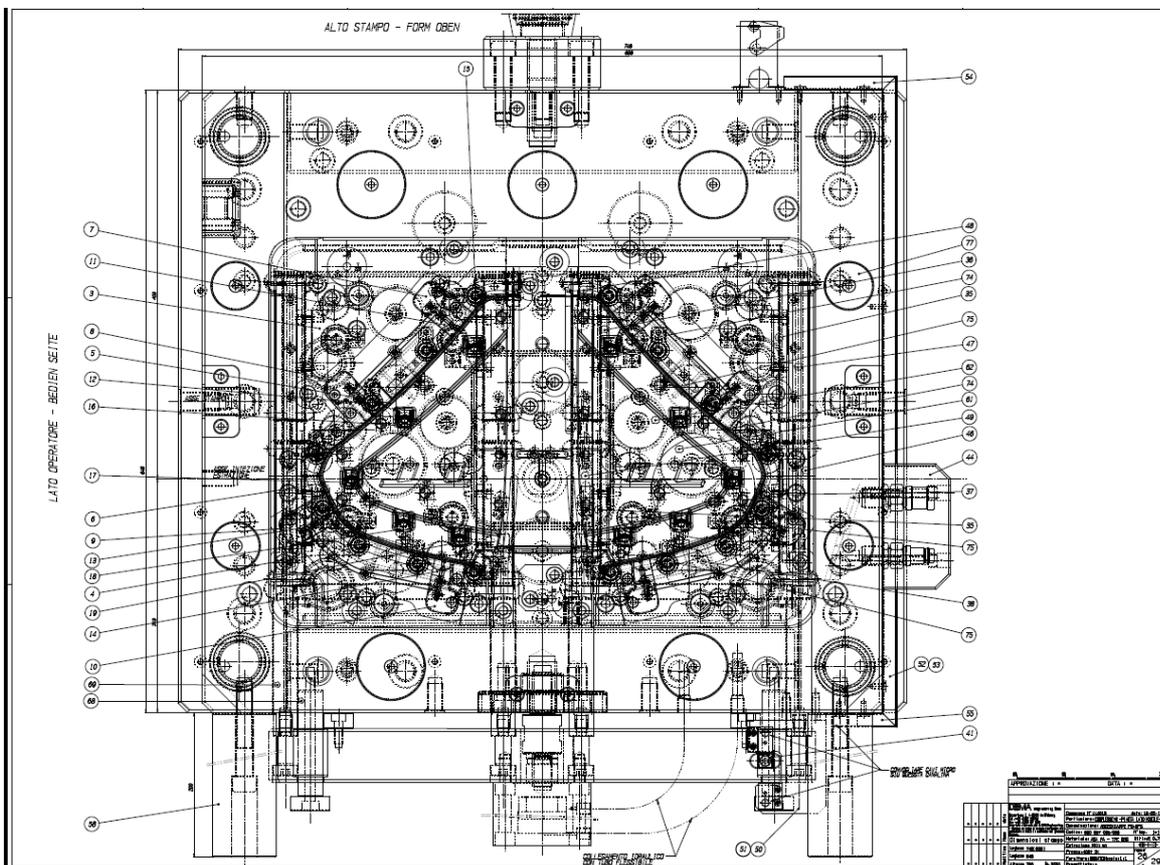
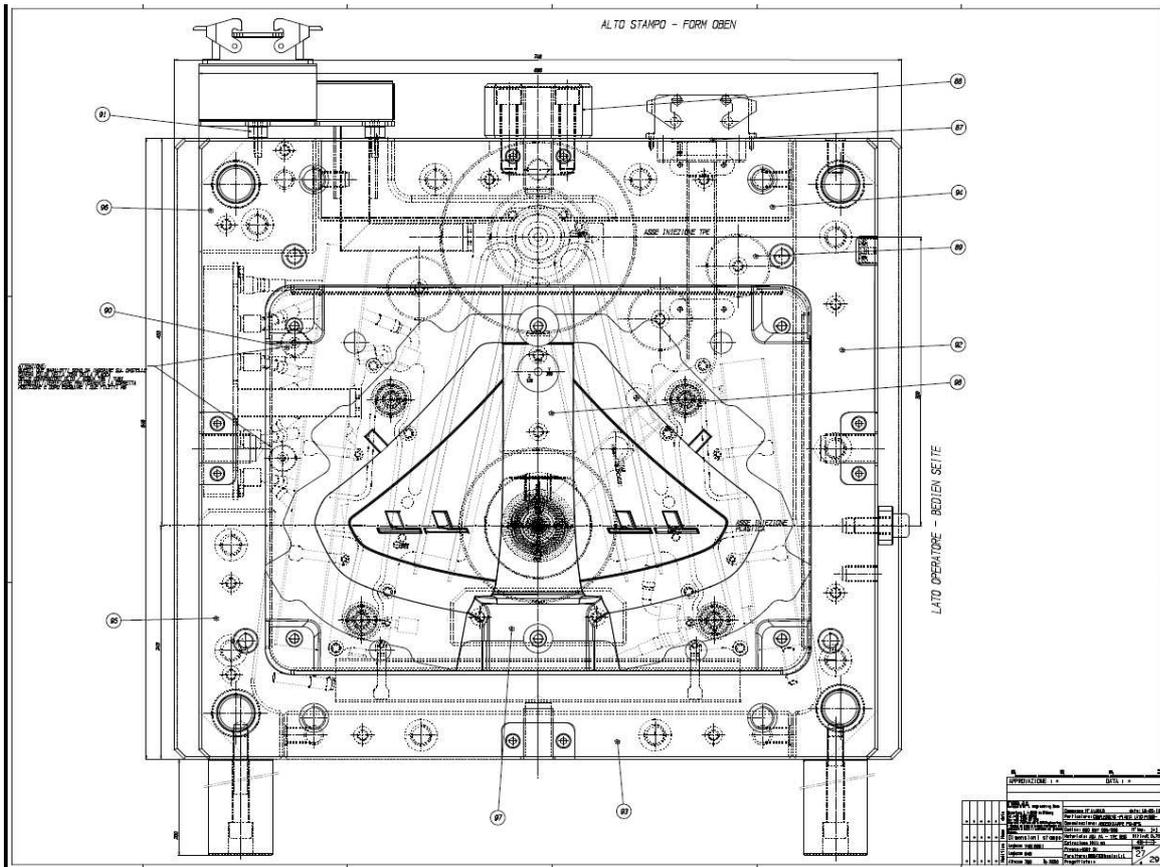

RRK-01 BMW Zuendspulenabdeckung 2K

1+1 IMPRESSIONS

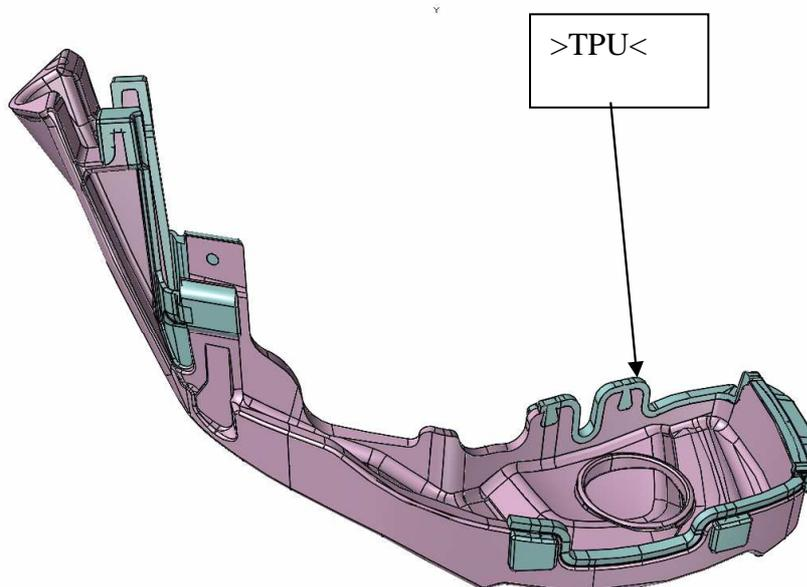
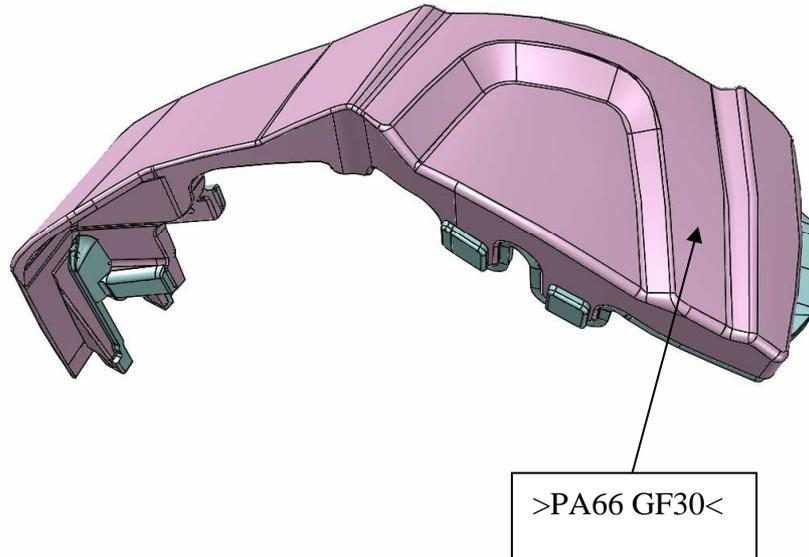

- TOOL FOR ROTATING PRESS PLATE
- TOOL SIZE 696X546X678H mm.
- PRESS ENGEL 250t

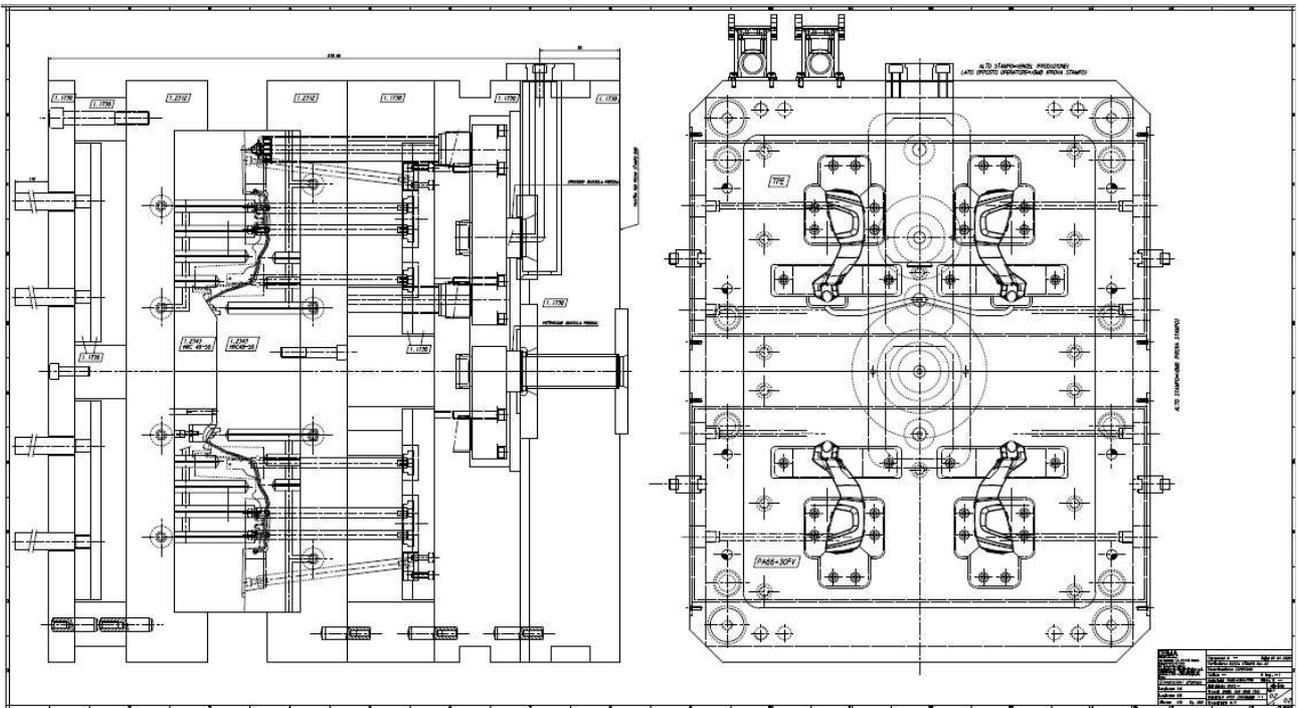
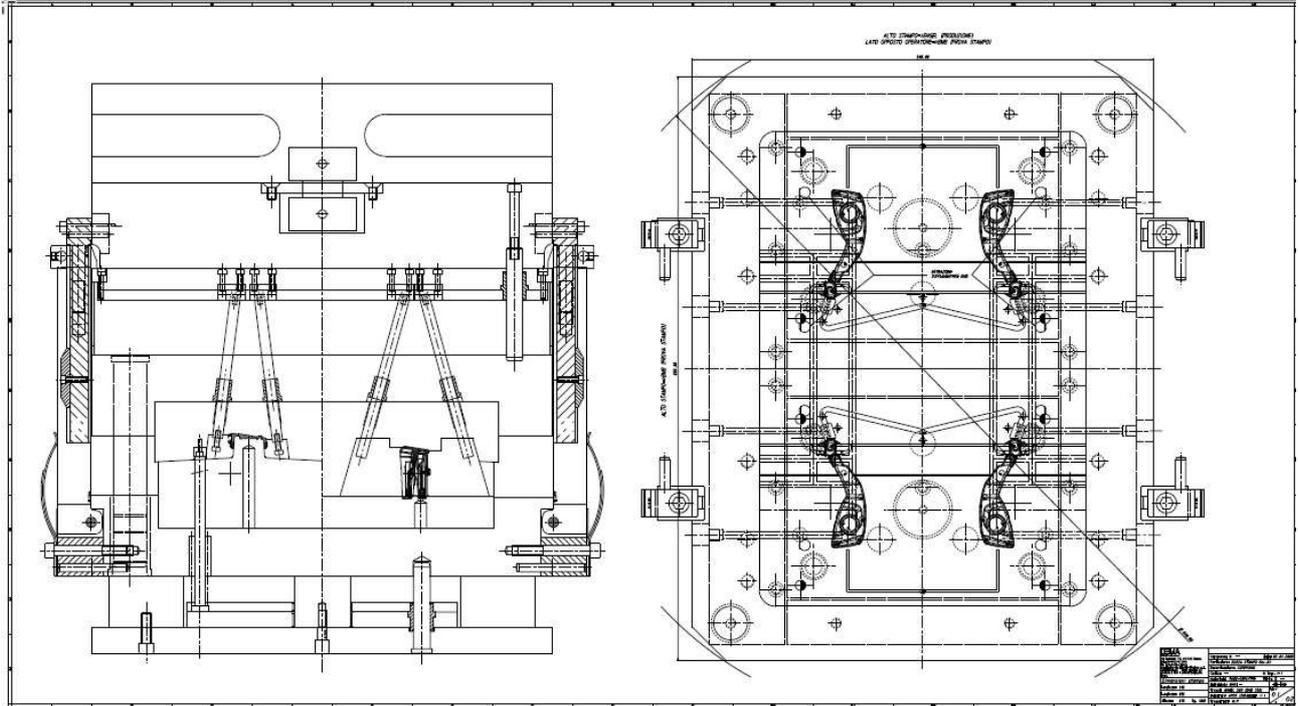

MK-01 Jaguar X351 D-Post Capping 2K

1+1 IMPRESSIONS

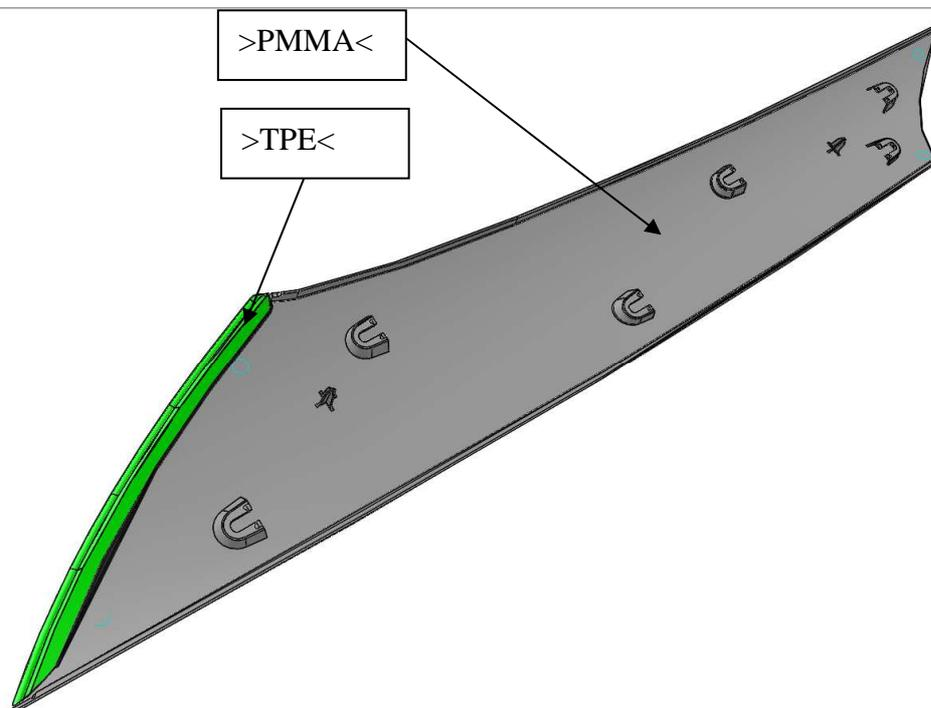
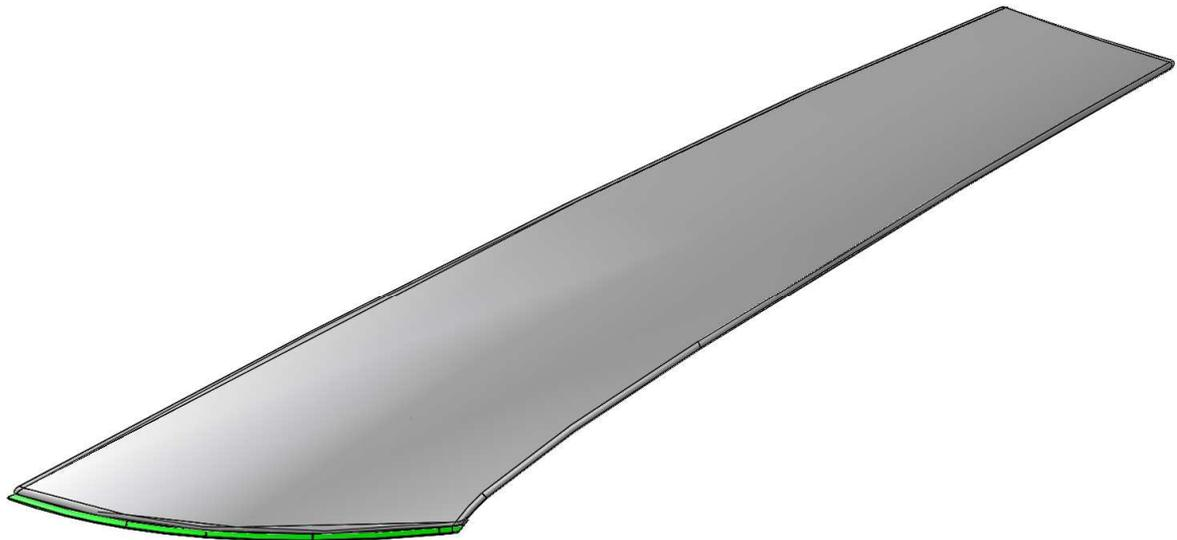

- TOOL WITH INJECTION UNIT ON TOP OF TOOL + BLADES MOVED BY HIDRAULIC CYLINDERS
- TOOL SIZE 1090X1340X1056H mm.
- PRESS NEGRIBOSSI 850t

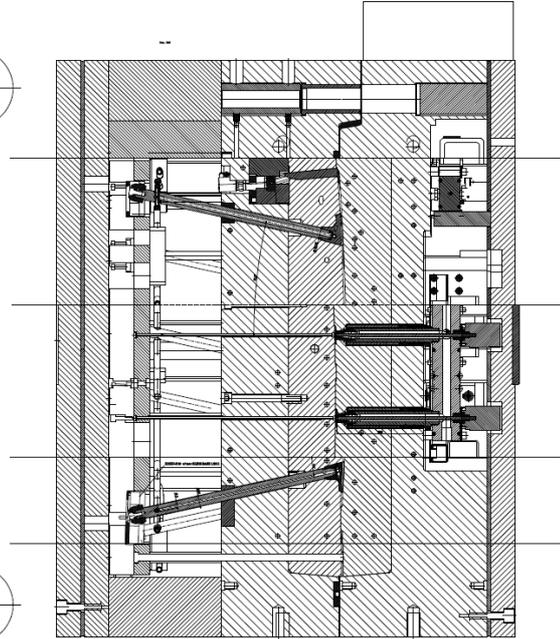
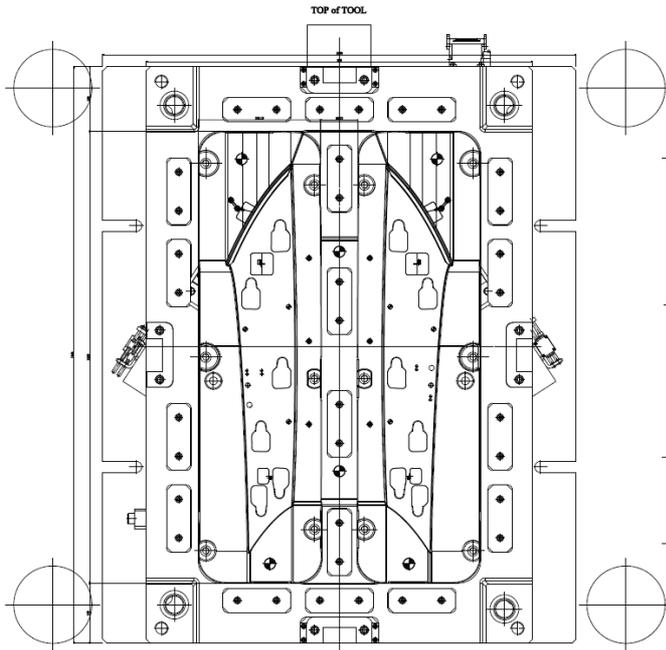

APPROVAZIONI		DATA	
PROVVISORIO/PROVISIONAL			
DEMA			
PROVVISORIO/PROVISIONAL			
DEMA			

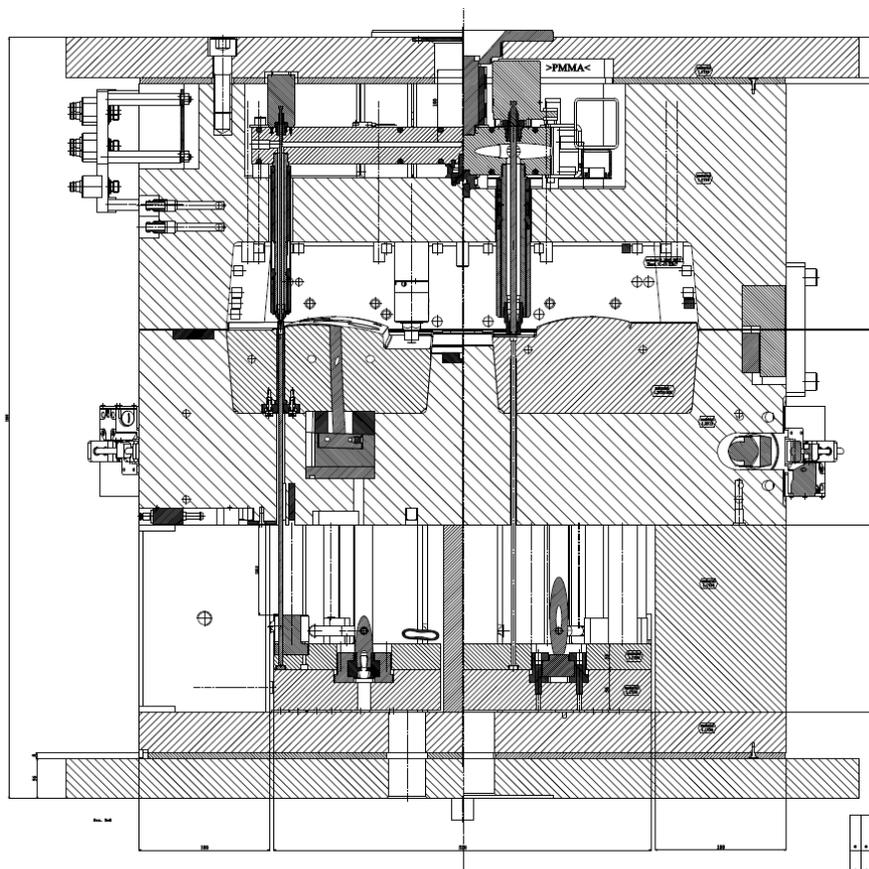

APPROVAZIONI		DATA	
PROVVISORIO/PROVISIONAL			
DEMA			
PROVVISORIO/PROVISIONAL			
DEMA			

Dimensioni stampo	Modello PMMA TPE 2000	443
Lunghezza	Spessore MMK	134
Larghezza	Presso	300 VERO
Altezza	Profilato	300x
		2
		30

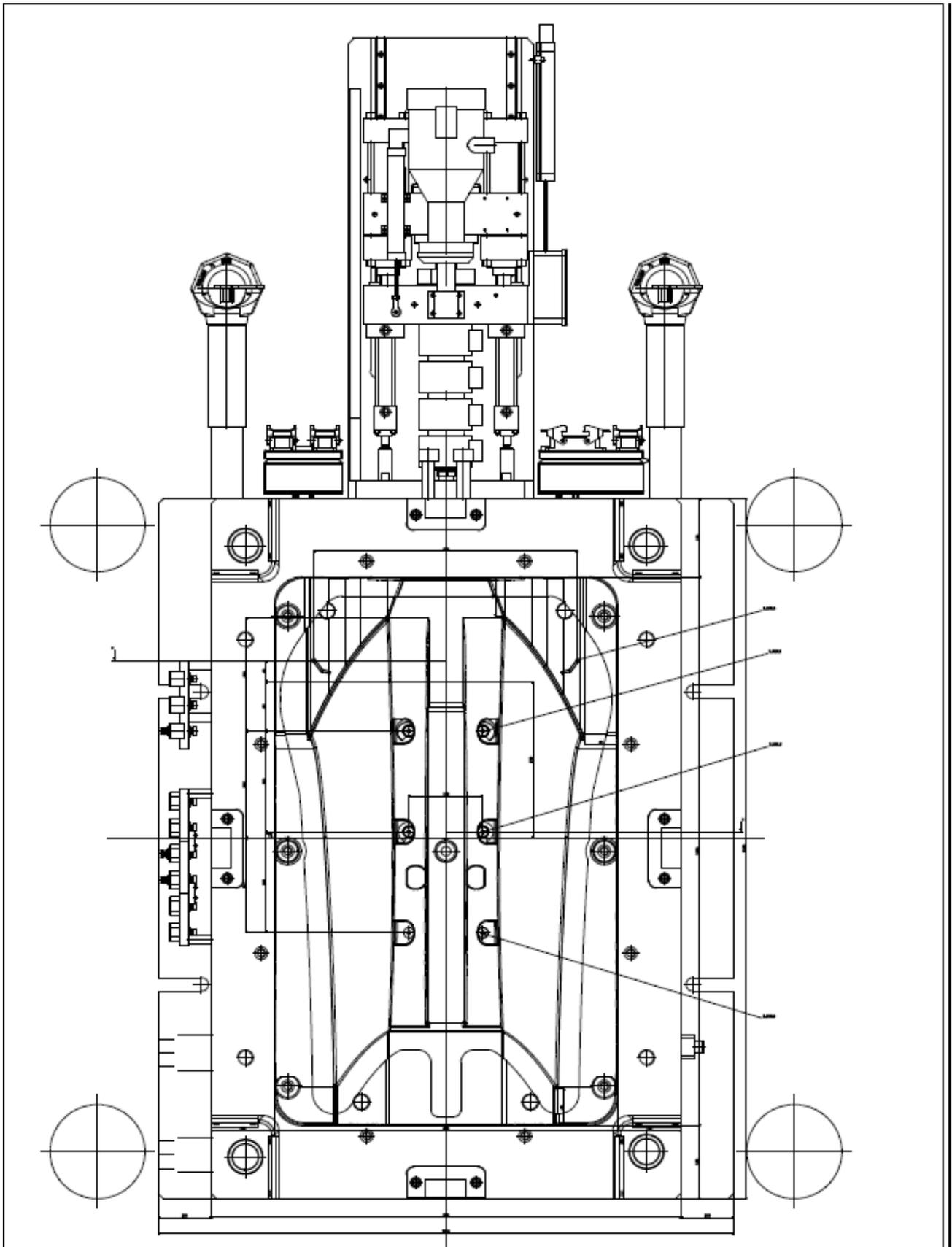

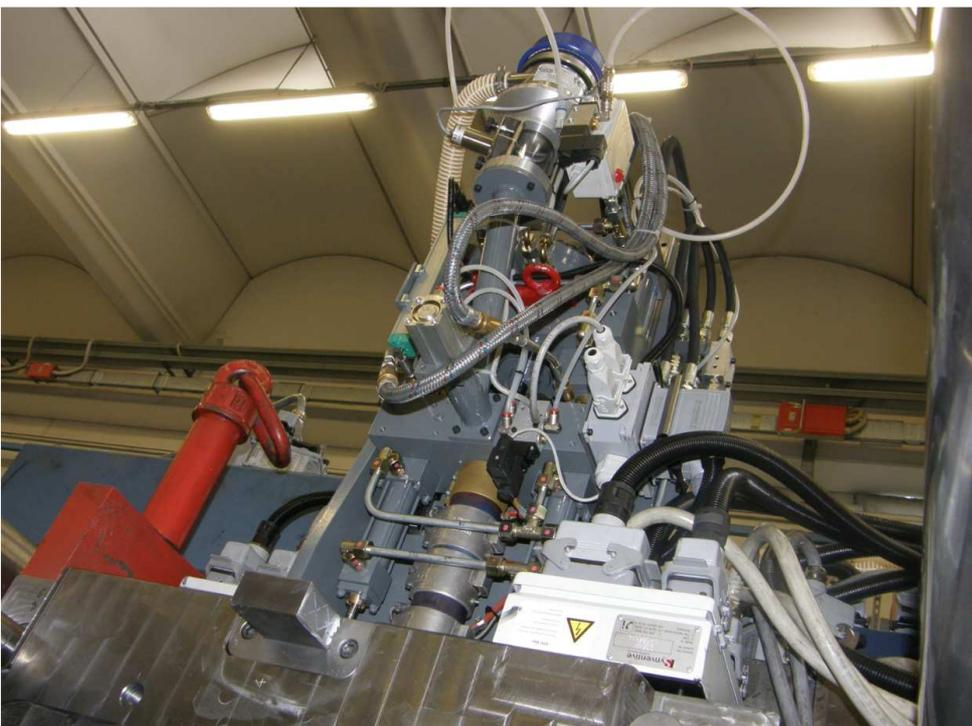

DA-10 MINI R56 BLENDE A-Saule

1+1 IMPRESSIONS

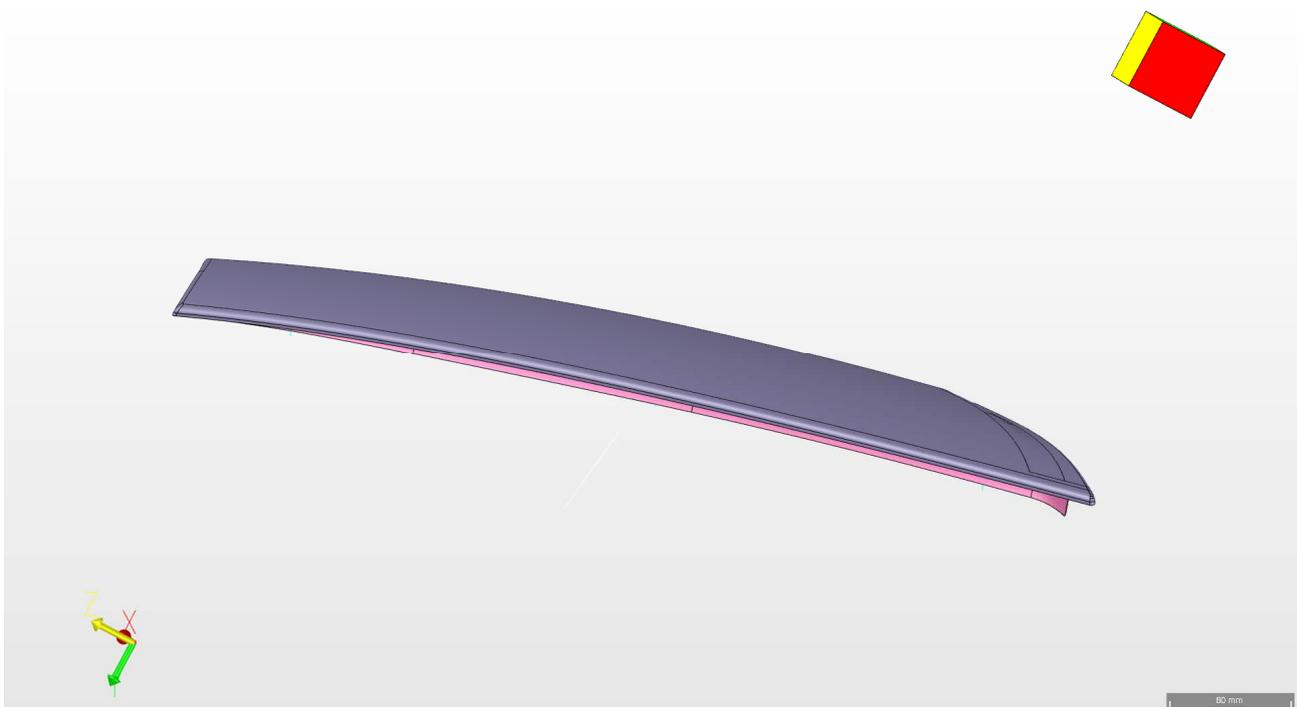
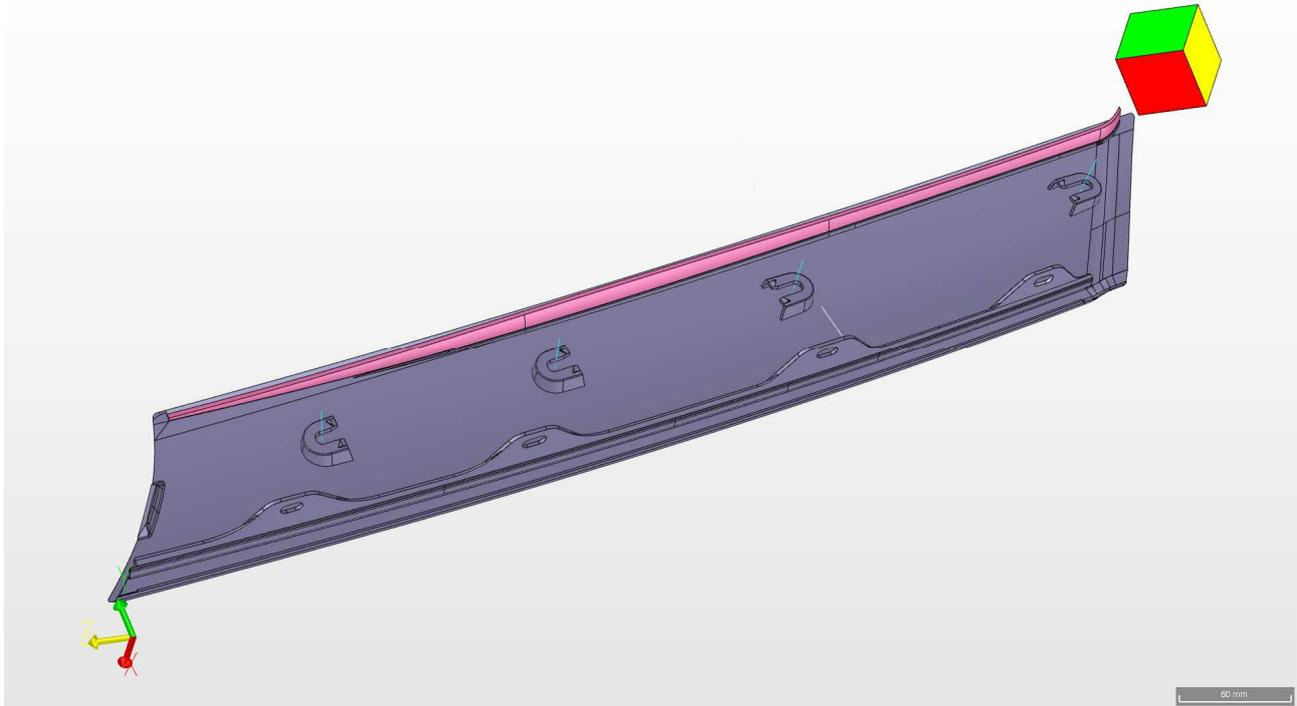

- TOOL WITH 2° INJECTION UNIT ON OPP. OPERATOR SIDE + BLADES MOVED BY HIDRAULIC CYLINDERS
- TOOL SIZE 1190X996X841H mm.
- PRESS KM1000t

